

OPERATION MANUAL

DESCRIPTION AND INTENDED USE OF THE DEVICE

The track lighting systems are based on the track. It is designed for mounting and supplying power to track lamps in AC networks with a rated voltage of 230V and a frequency of 50Hz. The track should be used indoors only in the absence of an aggressive environment and foreign aerosol particles at temperatures from 0°C to +50°C and relative humidity of not more than 80%.

There are options of wall and ceiling mounting made of normally flammable materials. It is possible to install the device using cable pendants. The track is supplied in 1 and 2 meter segments. It is possible to cut segments and form configurations of various shapes using connectors. Due to four current-carrying wires, the system based on this device enables to control separately the lamps located on the same track. Line selection is carried out by a special rotary mechanism on the track lamp adapter.

TECHNICAL DATA

Model	TRX005-311	TRX005-312
Mains voltage and frequency	~230V 50Hz	
Rated current	10A	
Protection class against electric shock	I	
Mounting method	surface/suspended	
Ingress Protection Code	IP20	
Climatic version	Boreal climate (4)	
Operating temperature	0°C - +50°C	
Housing material	Aluminum	
Color	black /white	
Segment length	1m	2m

PRECAUTIONS



All installation and mounting works must be carried out by persons with appropriate permits and qualifications. Contact a qualified electrician if necessary.

All installation and dismantling works must be carried out with a de-energized network only.

It is forbidden to operate the track without a protective ground wire.

When building-up a track system, do not exceed the total current load of consumers of 10A.

Do not install the track at a height below 2.5 meters, or in places where accidental human contact with the track may occur.

It is forbidden to operate the device with a damaged housing and with damaged insulation of the power cable.

The device is intended for indoor use only.

Do not use the device in rooms with high humidity and high levels of dust or aerosol particles in the air.

It is recommended to install lamps in increments of no more than 25cm per 1m of track.

Clean the device with a dry soft cloth with the mains power off. Do not use chemically aggressive cleaners.

ASSEMBLY DIAGRAM AND COMPLETE SET

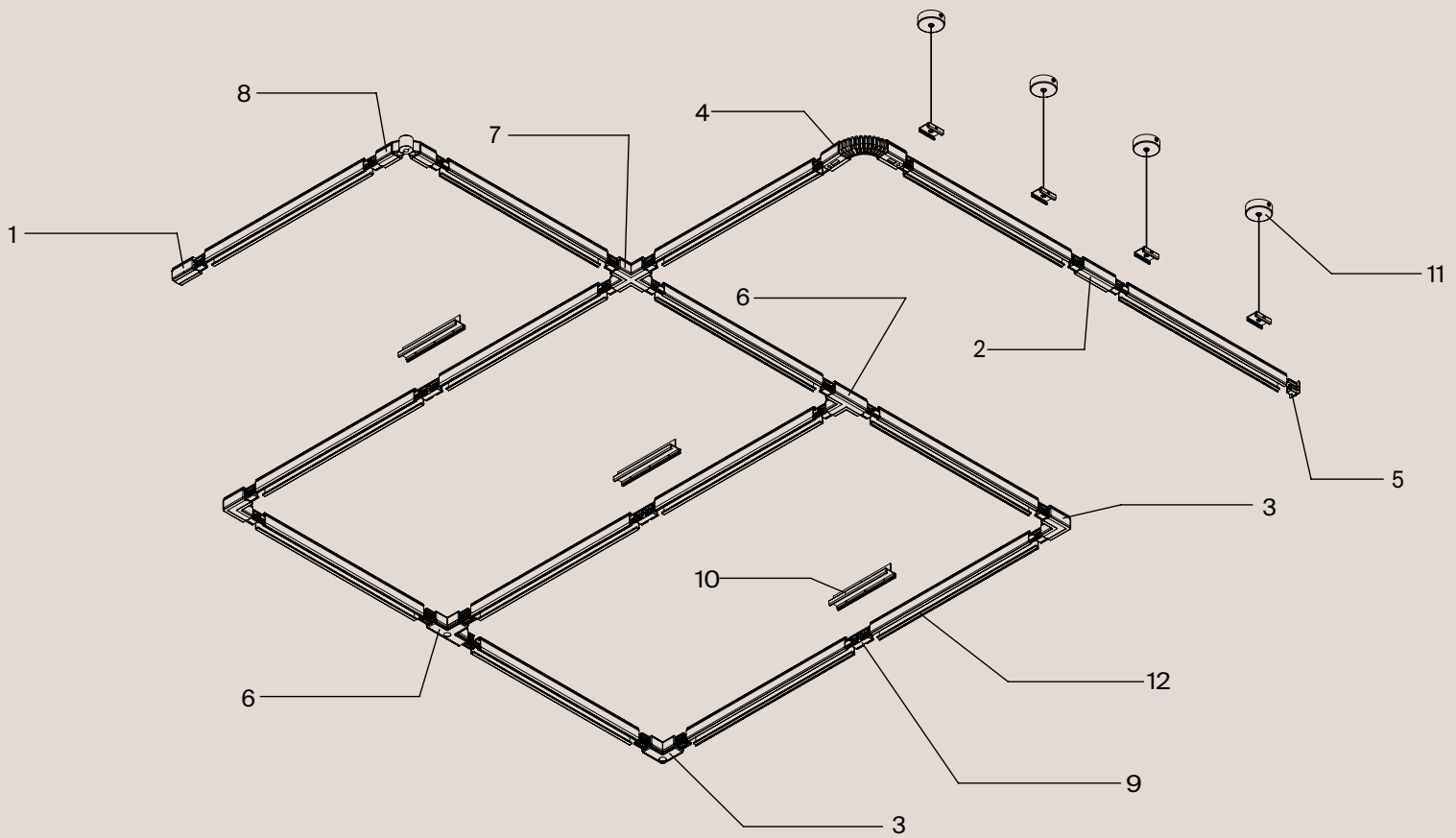

1 power input TRA005B-31B-R TRA005B-31B-L TRA005B-31W-R TRA005B-31W-L	2 straight connector TRA005C-31B TRA005C-31W	3 angle-connector* TRA005CL-31B-R TRA005CL-31B-L TRA005CL-31W-R TRA005CL-31W-L	4 flexible connector TRA005CF-31B TRA005CF-31W	5 plug TRA005EC-31B TRA005EC-31W	6 T-shaped connector** TRA005CT-31B-R TRA005CT-31B-L TRA005CT-31W-R TRA005CT-31W-L
7 X-shaped connector TRA005CX-31B TRA005CX-31W	8 swivel connector TRA005CS-31B TRA005CS-31W	9 inner straight connector TRA005CI-31B TRA005CI-31W	10 joint amplifier TRA005TL-31B TRA005TL-31W	11 cable suspension TRA005WS-31B TRA005WS-31W	12 track TRX005-311B TRX005-311W TRX005-312B TRX005-312W

*L - external, R - inner

**L - external Left, R - inner right

ASSEMBLY DIAGRAM AND COMPLETE SET

The following components and accessories are used to form complex configuration systems:

1

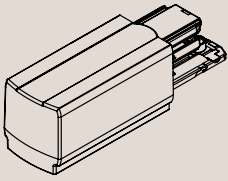

Power input - a structural element that is used to supply power to the system. Depending on the location of the ground contact, it can be right or left. This accessory is completed with each segment of track (right).

2

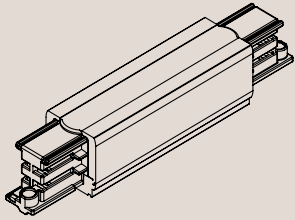

Straight power connector - an accessory used to connect individual segments of track in a straight line with power input.

3

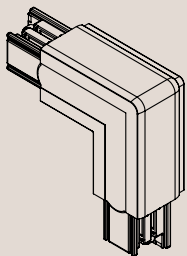

Angle connector - a system element used to connect track segments at an angle of 90°. The location of the ground contact in this accessory can be either on the inside or on the outside of the connector angle. This should be taken into account when selecting and assembling systems of rectangular and polygon shapes.

4

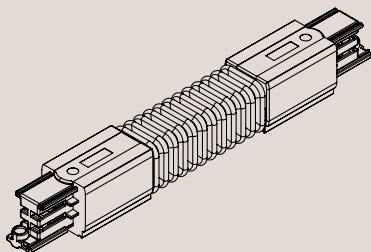

Flexible connector - a system element, which is used in cases where the connection requires a complex bend or an arbitrary angle between the joined segments of the track.

5

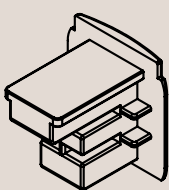

End plug - an accessory necessary both for safe installation to prevent damage to wires, decorative elements of interior and to avoid injury from the sharp edges of the track, and for a decorative purpose, closing the open end of the track, therefore it is included with each segment of the track.

6

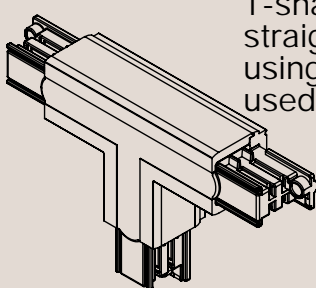

T-shaped connector - a system element used to organize branches from straight sections of the track system to the left or right with power input. When using this accessory in closed structures, only external angle connectors can be used.

ASSEMBLY DIAGRAM AND COMPLETE SET

7

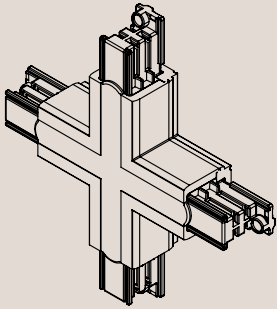

X-shaped connector - a system element used to form configurations of complex shape for branches in 3 directions with power input.

8

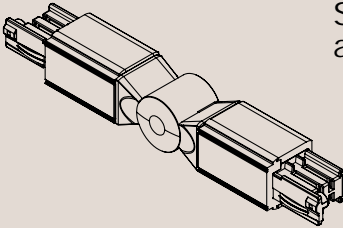

Swivel connector - an accessory that is used to connect track segments at an arbitrary angle, while maintaining rigidity.

9

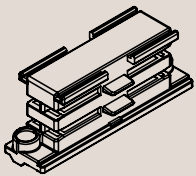

Inner straight connector - an accessory used to connect individual segments of the track into a straight line.

10

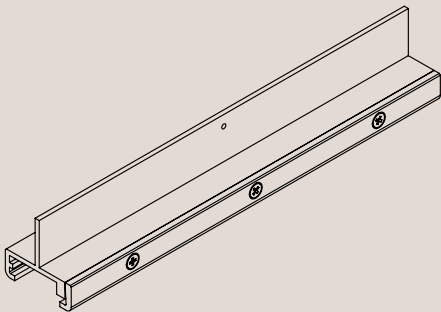

Joint amplifier - an accessory that is used for rigid fixation of joints when the track is suspended. It is used together with cable pendant, if the attachment point coincides with the butt joint of track segments.

11



Cable suspension kit - this accessory is required when the track is installed in a suspended way. The kit includes a cable with collet clamps, a mounting plate, a ceiling bowl.

12

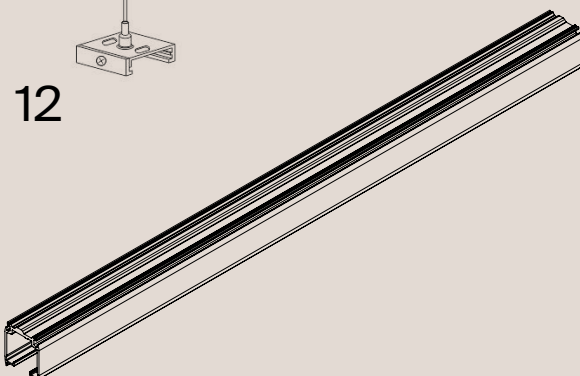

The track is the main element of the system, it contains current-carrying conductors, and the housing design allows fixing track lamps on it.

TRACK CONNECTION METHODS

SINGLE LINE CONNECTION:

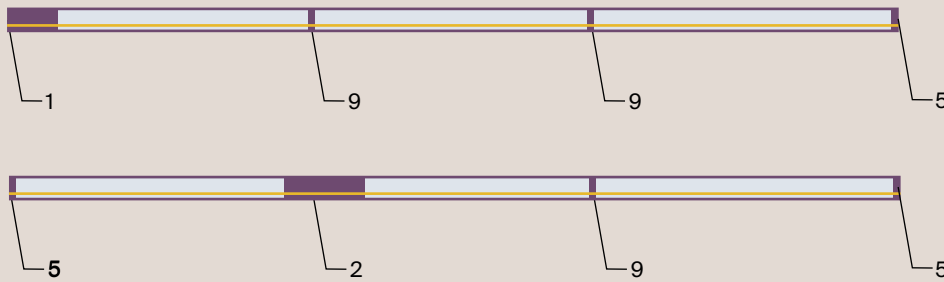

There are two examples of connection in a straight line. The top version uses a power input, while the bottom version uses a direct connector with input option, which allows supplying power to the system from any convenient point.

POLYLINE CONNECTION:

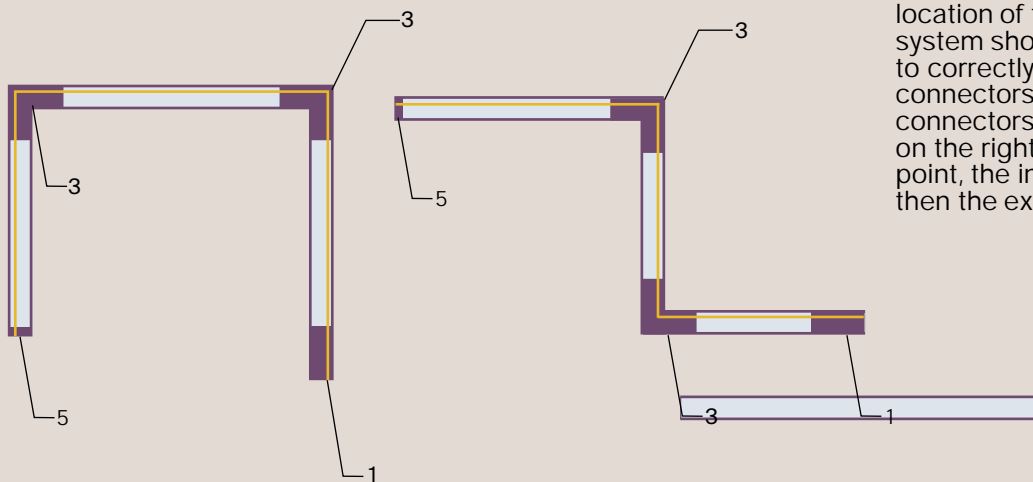

When forming polyline connections, the location of the ground contact throughout the system should be taken into account in order to correctly select the suitable angle connectors. On the left version, all angle connectors are external, and on the right version, from the power input point, the inner angle connector goes first, and then the external ones.

CONNECTION AT ARBITRARY ANGLE:

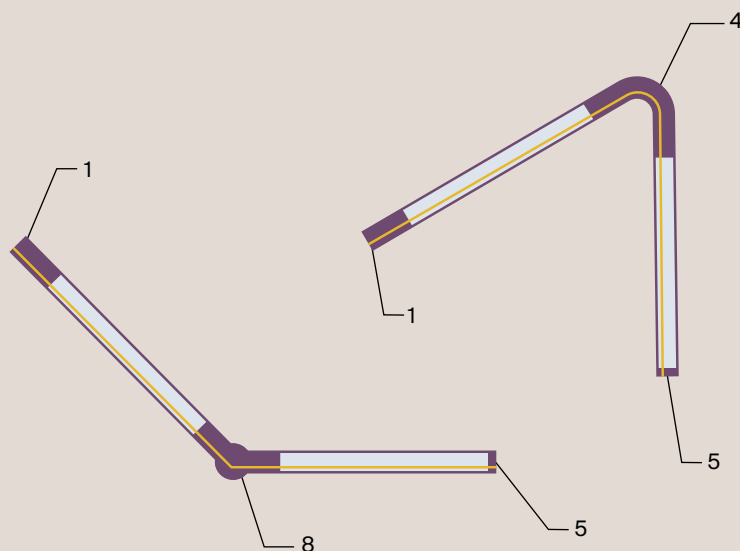

To the extent that a configuration with angles other than 90° is required, flexible or swivel connectors are used. The flexible connector allows bending both in the horizontal and vertical planes, the swivel connector is used in the horizontal plane only.

1 powerinput TRA005B-31B-R TRA005B-31B-L TRA005B-31W-R TRA005B-31W-L	2 straight connector TRA005C-31B TRA005C-31W	3 angle-connector* TRA005CL-31B-R TRA005CL-31B-L TRA005CL-31W-R TRA005CL-31W-L	4 flexible connector TRA005CF-31B TRA005CF-31W	5 plug TRA005EC-31B TRA005EC-31W	6 T-shaped connector** TRA005CT-31B-R TRA005CT-31B-L TRA005CT-31W-R TRA005CT-31W-L
7 X-shaped connector TRA005CX-31B TRA005CX-31W	8 swivel connector TRA005CS-31B TRA005CS-31W	9 innerstraight connector TRA005CI-31B TRA005CI-31W	10 joint amplifier TRA005TL-31B TRA005TL-31W	11 cable suspension TRA005WS-31B TRA005WS-31W	12 track TRX005 -311B TRX005 -311W TRX005 -312B TRX005 -312W

TRACK CONNECTION METHODS

RECTANGULAR JOINT:

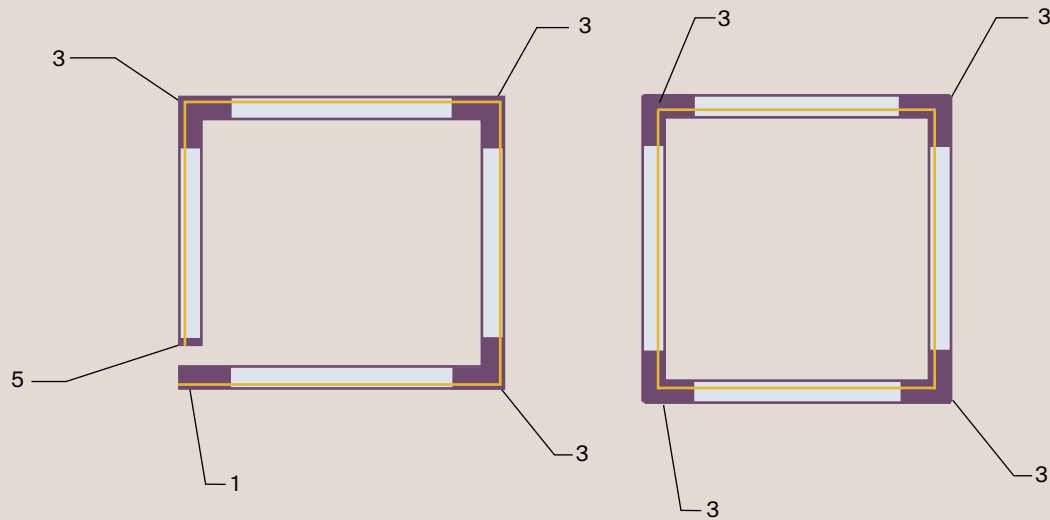

Rectangular track system configurations can be manufactured in both open and closed versions. It should be taken into account that the angle connectors can be either external or internal.

T-JOINT AND X-JOINT:

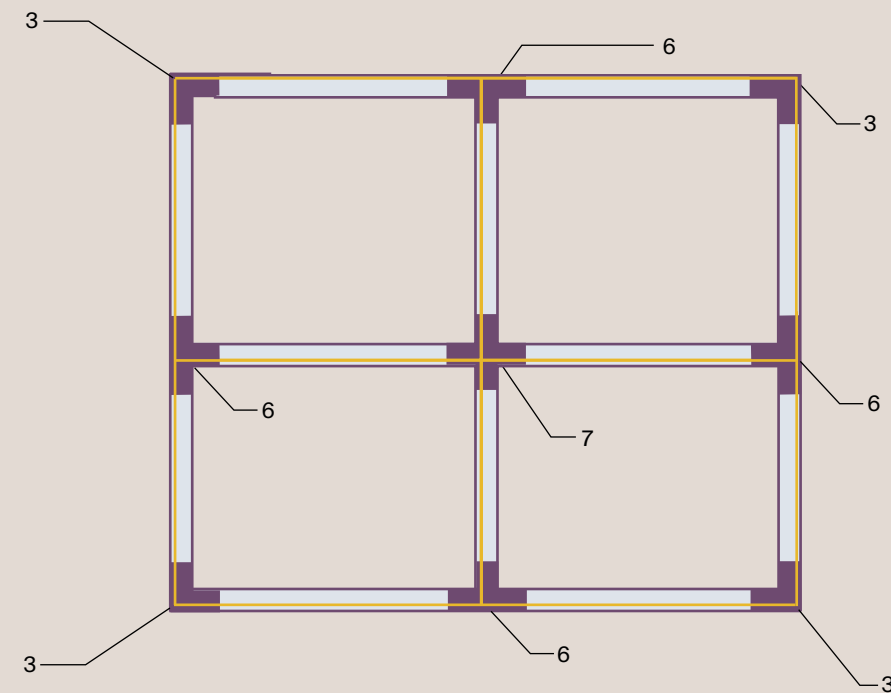

When forming track systems of a complex configuration, it is possible to use both X-shaped and T-shaped connectors. To connect all branches, as in this example, angle connectors are required. If there are T-shaped connectors in the system, only external angle connectors should be used. On opposite sides of the system, multidirectional T-shaped connectors should be used (if the left one is inserted on one side, then the right one is installed opposite it).

1 powerinput TRA005B-31B-R TRA005B-31B-L TRA005B-31W-R TRA005B-31W-L	2 straight connector TRA005C-31B TRA005C-31W	3 angle-connector* TRA005CL-31B-R TRA005CL-31B-L TRA005CL-31W-R TRA005CL-31W-L	4 flexible connector TRA005CF-31B TRA005CF-31W	5 plug TRA005EC-31B TRA005EC-31W	6 T-shaped connector** TRA005CT-31B-R TRA005CT-31B-L TRA005CT-31W-R TRA005CT-31W-L
7 X-shaped connector TRA005CX-31B TRA005CX-31W	8 swivel connector TRA005CS-31B TRA005CS-31W	9 innerstraight connector TRA005CI-31B TRA005CI-31W	10 joint amplifier TRA005TL-31B TRA005TL-31W	11 cable suspension TRA005WS-31B TRA005WS-31W	12 track TRX005-311B TRX005-311W TRX005-312B TRX005-312W

MOUNTING PROCEDURES

MOUNTING ON A RIGID SURFACE BY OVERLAP METHOD

The maximum allowable load per track segment is 20 kg. Distance between fasteners - no more than 80 cm.

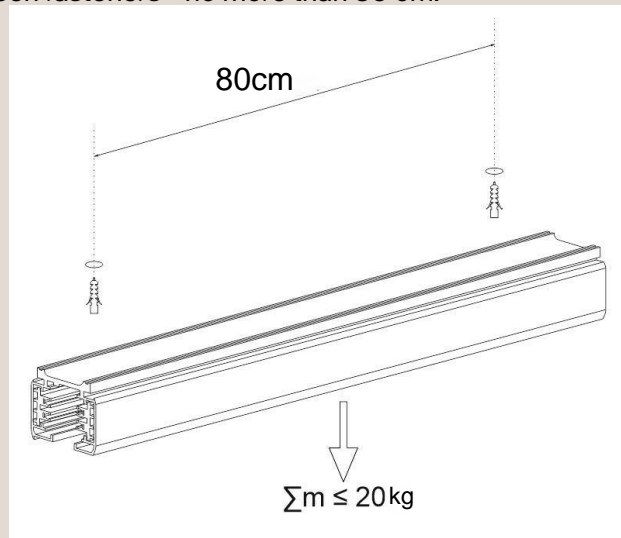

MOUNTING ON CABLE PENDANT

The maximum allowable load per track segment is 20 kg. Distance between fasteners - no more than 1 m.

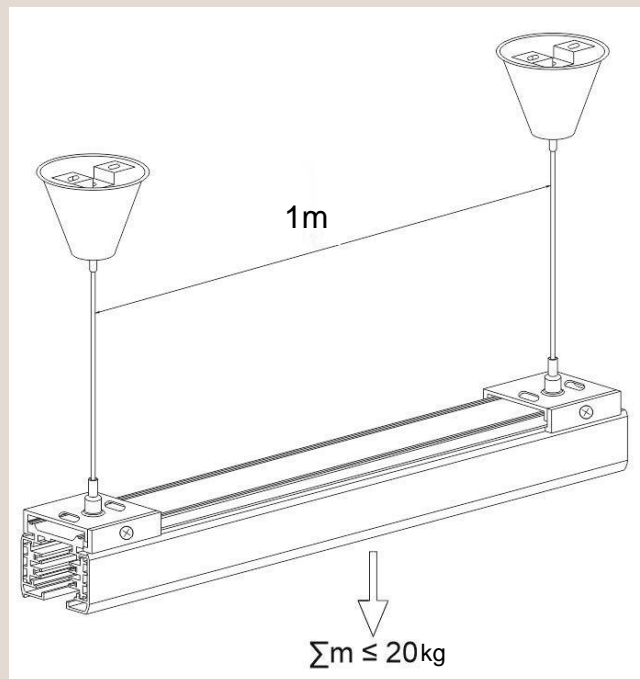

MOUNTING PROCEDURES

1. Unpack the track and visually inspect for possible defects.
2. Mark and prepare the holes on the track and mounting surface, depending on the mounting method.
3. Determine the power input point to the track. Lead the five-core power cable to the installation site.
4. Connect the power through the power input, or any suitable structural element (angle connector, X-shaped connector, etc.)
5. Attach the track to the surface using screws, brackets, wood screws, self-tapping screws, or other suitable fasteners.

ATTENTION!

When fixing the track to the surface, it is necessary to select fasteners that correspond to the material and provide a tight connection to it.

TRACK INSTALLATION

MOUNTING THE TRACK WITH THE PENDANT

For suspended installation of the track, it is necessary to use special pendant kits, TRA005WS-31B / TRA005WS-31W, consisting of a cable with collet clamps that allow you to adjust its length, mounting and clamping plates and a decorative cap.

1. Prepare the mounting surface and mark it out. Drill holes, put dowels in them.
2. Place the mounting plate on the surface, fix it with screws.
3. Close the mounting plate with a decorative cap, fix it with the supplied screw.
4. Pass the cable through the collet, adjust the length. If necessary, cut off excess cable. Loosen the side screw on the pressure plate.
5. Mount the track on the clamping plates by inserting them into the groove on the back side. Tighten the side screw on the clamping plate. Check the horizontal plane with a builder's level. Avoid skewness, if necessary, adjust the length of the cables additionally.

NOTE

During suspended installation of several connected segments of the track, they should be placed strictly in a horizontal plane, avoiding skewness and uneven tension of the cables. To ensure rigid fixation of track segments in a line, an additional element is used - joint amplifier TRA005TL-31B / TRA005TL-31W.

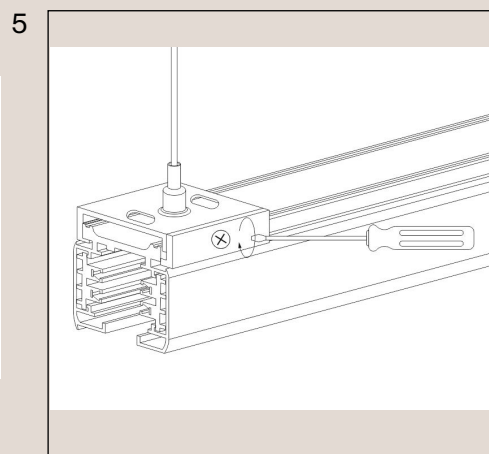
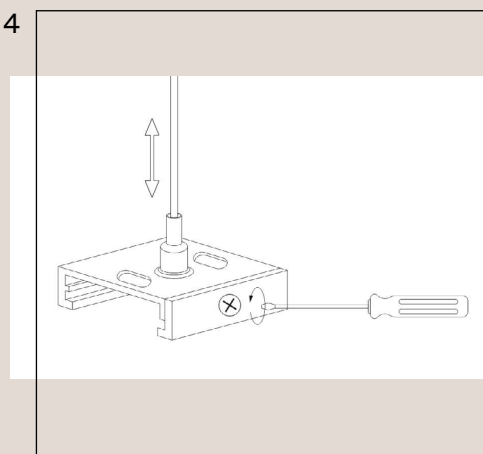
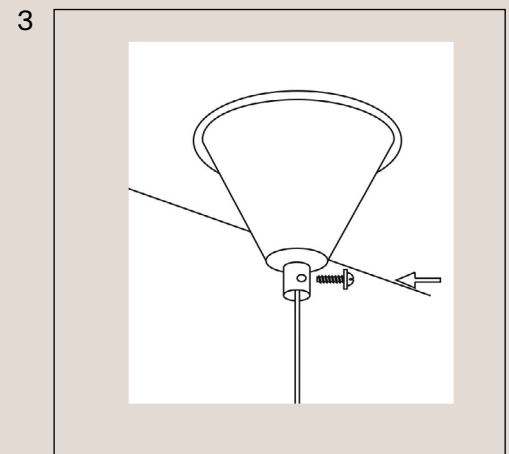
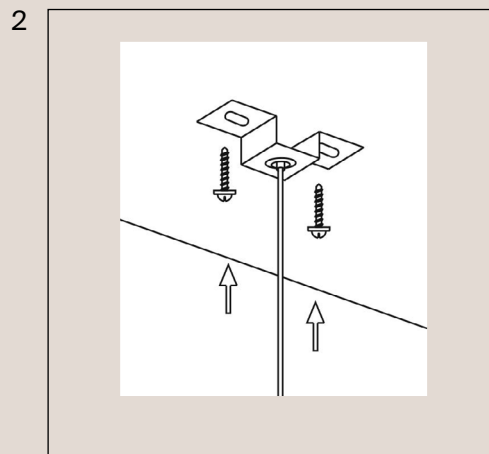
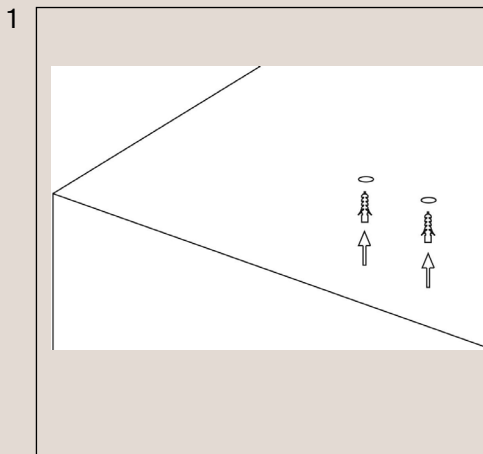

TRACK INSTALLATION

INSTALLATION OF A THREE-PHASE TRACK USING A PROFILE FOR A STRETCH CEILING

In addition to surface and suspended mounting, it is possible to install the track in a profile for a stretch ceiling (Not included in the product range, sold separately.). To implement this option, in addition to the three-phase track, profile is purchased and the installation is carried out as follows:

1. Cut the profile and track to the required length.
2. Drill mounting holes and cable entry holes.
3. Assemble all parts of the profile and track, if necessary, install plugs.
4. Fasten the profile to the surface using the mounting brackets.
5. Stretch the ceiling fabric and glue the edges of the harpoons along the entire length of the profile.
6. Make a slot between the harpoons.

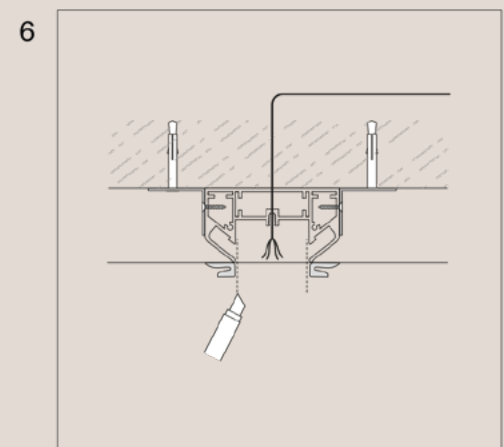
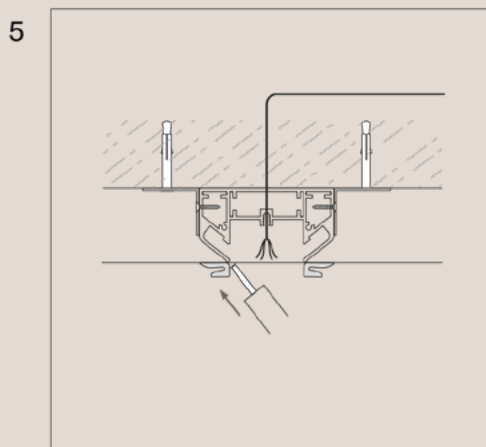
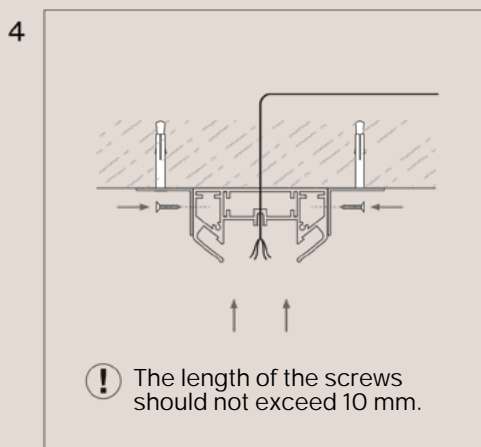
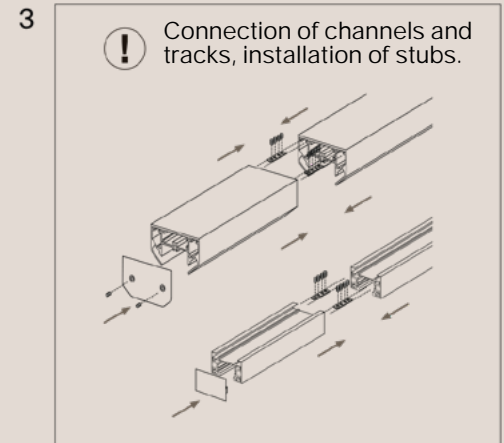
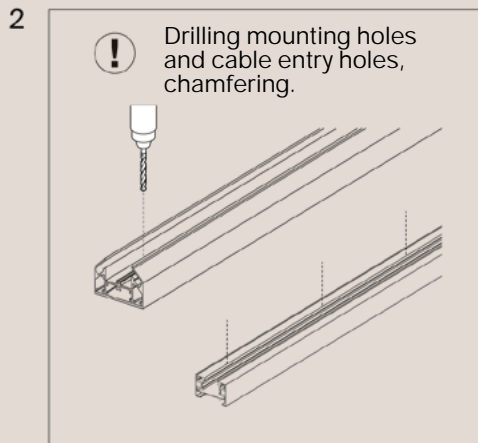
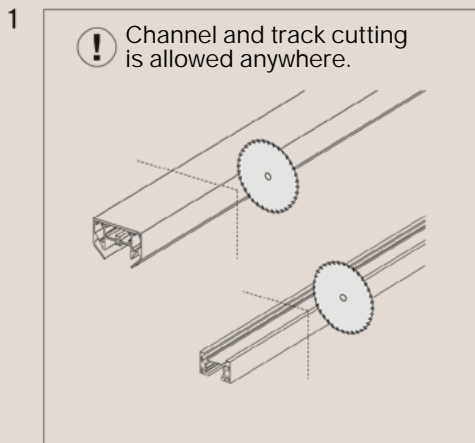

ATTENTION!

Installation of the track using this profile is possible only with the use of PVC fabrics for stretch ceilings.

TRACK INSTALLATION

INSTALLATION OF A THREE-PHASE TRACK USING A PROFILE FOR A STRETCH CEILING

7. Fill the harpoons into the grooves of the profile and glue the ends.
8. Install the track and fasten it to the profile.
9. The track is ready for operation and installation of lampson it.

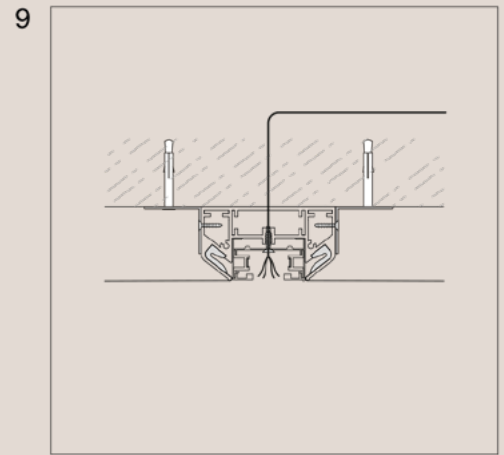
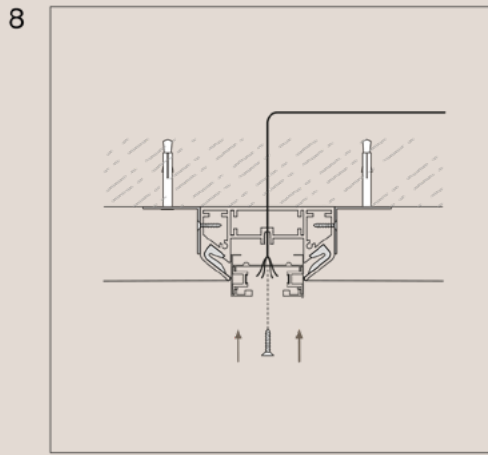
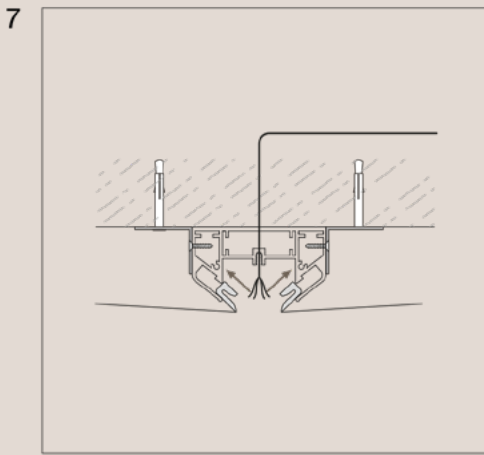

LOCATION OF TERMINALS AND CONNECTOR CONNECTION

RECOMMENDATIONS

For the correct connection and selection of components, the location of the neutral conductor in the track should be taken into account. To facilitate the correct assembly of the track system, a special ledge is provided in the track design - it will serve as a reference point for the location of the neutral. On track, "neutral" (N) is the bus located on the side of the ledge of the housing. Power input and selection of all other accessories is based on the fact that the connector will be inserted into the track, marking the neutral conductor with the corresponding indicator. To do this, all connectors designed for track branches are available in 2 versions - right R or left L.

Choose the appropriate method of mounting the track based on this, mark the attachment points to the surface or the location of the cable pendants, taking into account that during surface mounting, the distance between the fixing points should not exceed 80 cm, and the distance between the pendants should not exceed 1 m.

A properly mounted track enables to withstand a uniform load of no more than 20 kg per segment, but the fact that the lamps during operation are able to heat each other should be taken into account and it is recommended to install them on the track in increments of no more than 25 cm.

The following signs will help you make the correct choice of components with the optimal location of the "neutral", so as not to break the circuit.

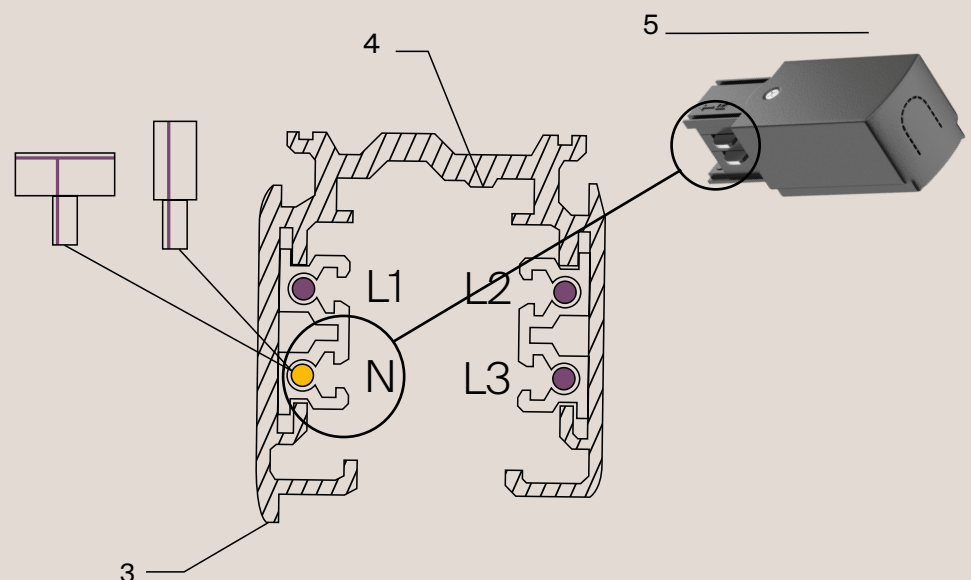

- 1 Current conductors
- 2 Neutral conductor
- 3 Neutral conductor location indicator

- 4 Ground contact bus
- 5 Cable entry point

ATTENTION!

Incorrect connection of components to the track can lead to a breakdown of the track itself and to the failure of the track lights located on it!

CONNECTING THE TRACK TO THE NETWORK

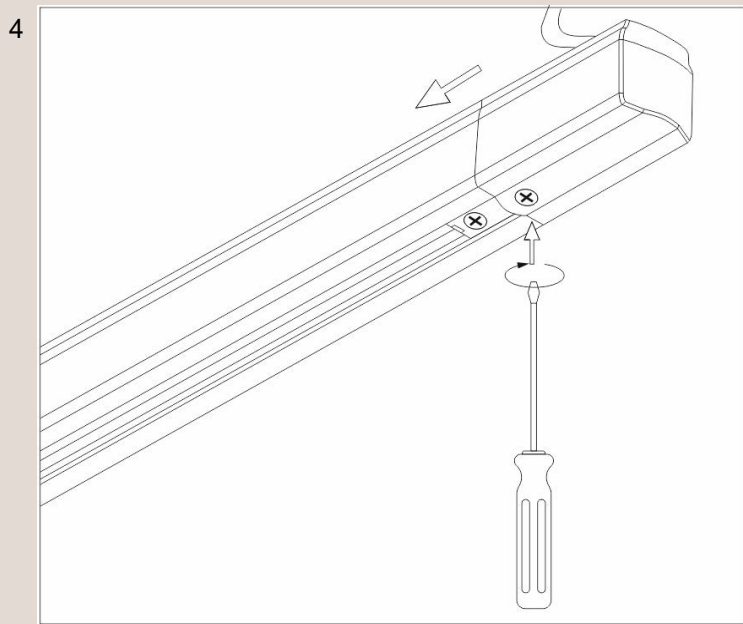
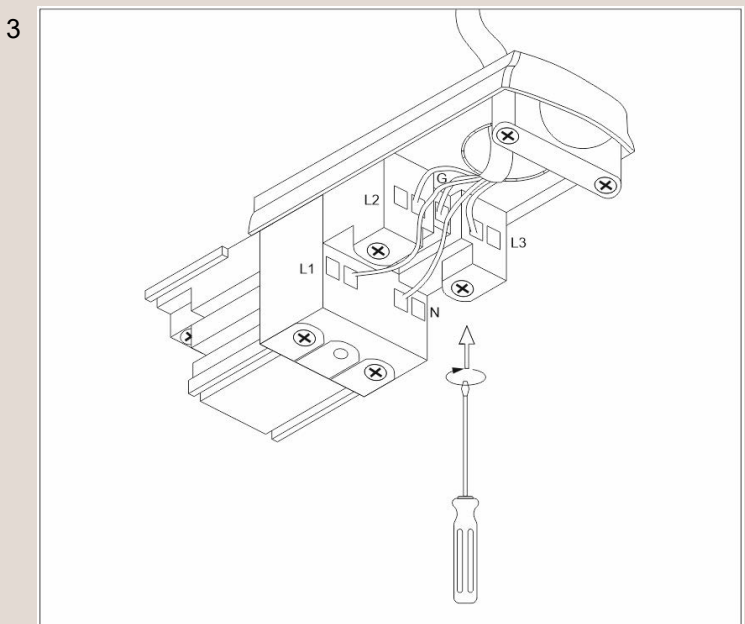
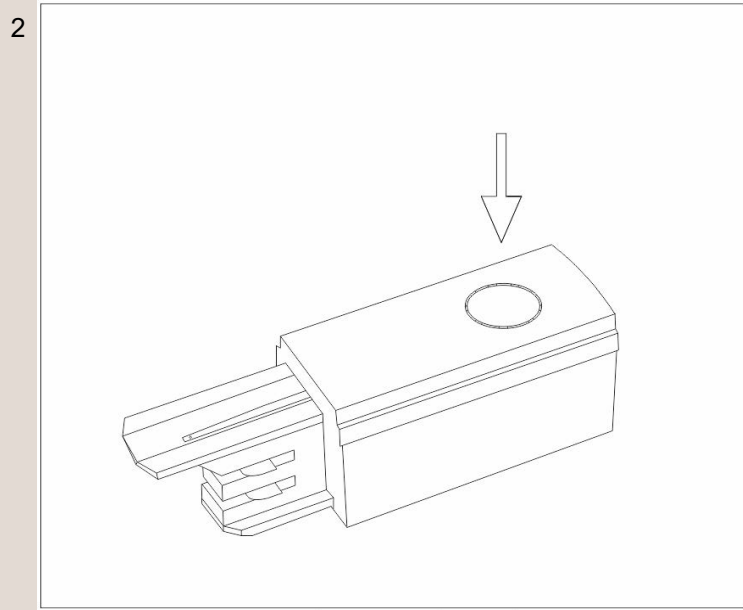
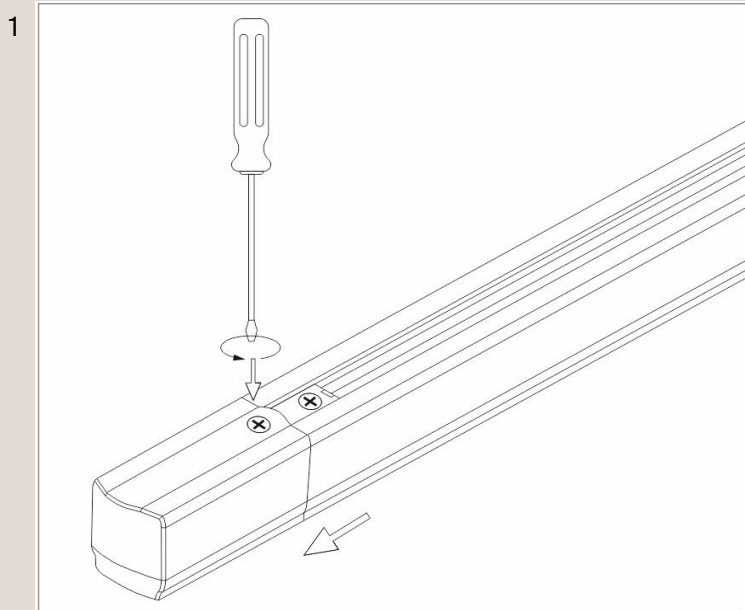

1. Remove the power input from the track, unscrew the fixing screws.
2. Make a hole for the power cable by removing the special insert on the back side of the power input, remove the cover.
3. Pass the five-core power cable through the hole and connect the wires according to the marking of the contact screw terminals: yellow-green wire to the G terminal, blue to the N terminal, brown, white, black, etc. to the L1, L2, L3 terminals.
4. Close the cover by fixing it with a screw and insert the connected power input to the mounted track.

NOTE

It is possible to connect the track to the network not only using the power input, but also using the following accessories: TRA005C-31, TRA005CL-31, TRA005CT-31, TRA005CX-31, thus making connections in any convenient place.

SELECTING THE CONNECTION DIAGRAM

The connection diagram determines how the lighting fixtures located on the track will be controlled, below are the options for the applied diagrams.

1

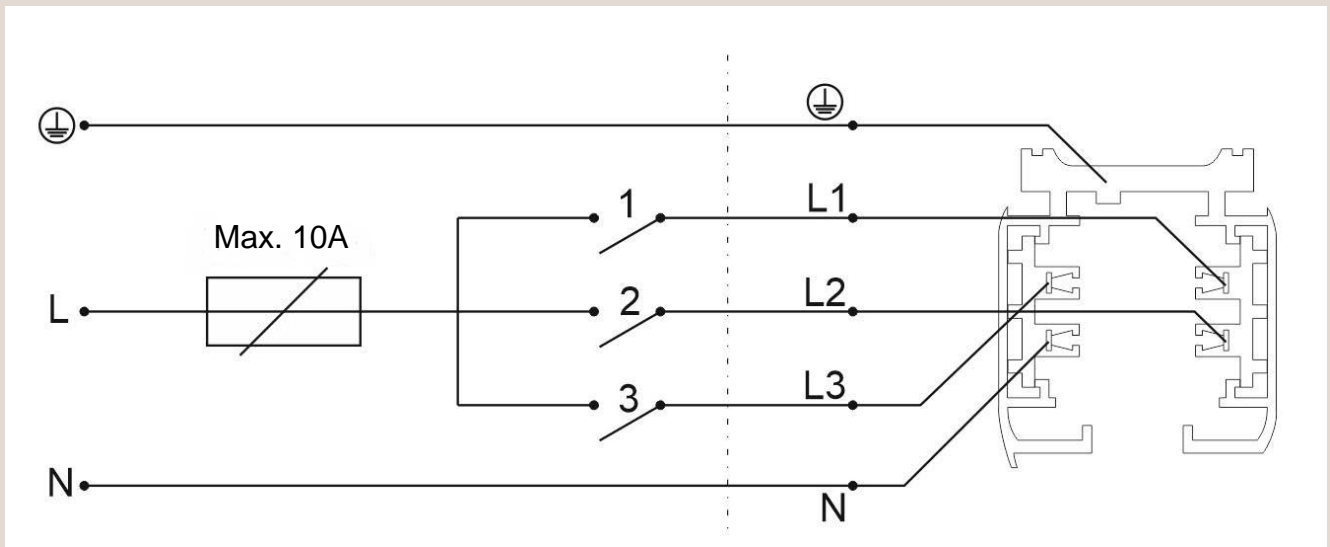

One line, in which the control is divided by means of single-gang switches.

2

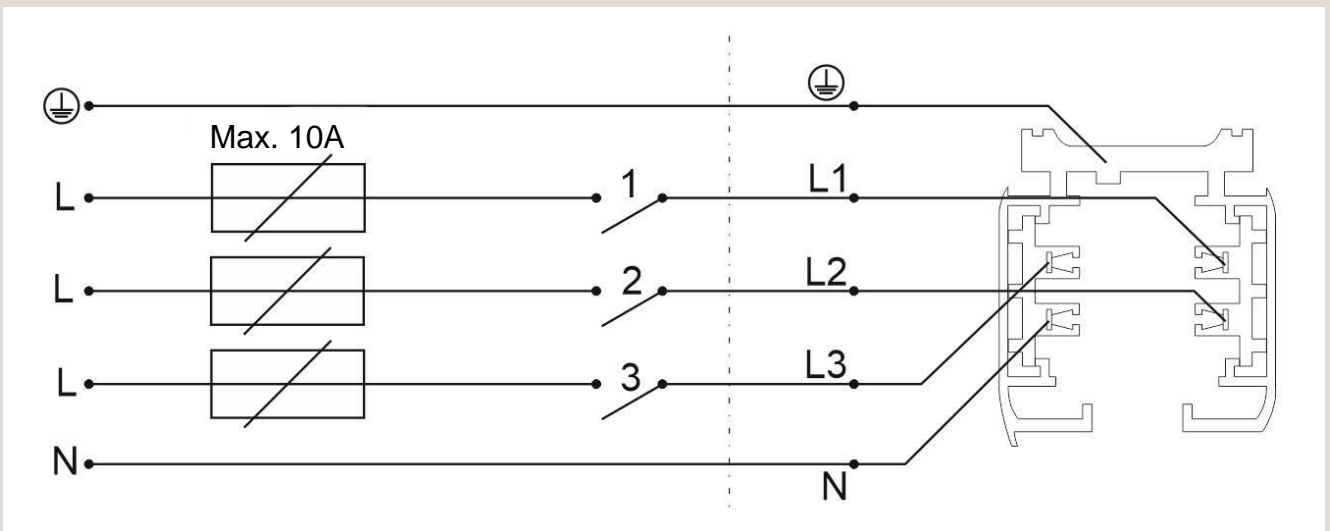

Three independent lines controlled by single-key switches.

3

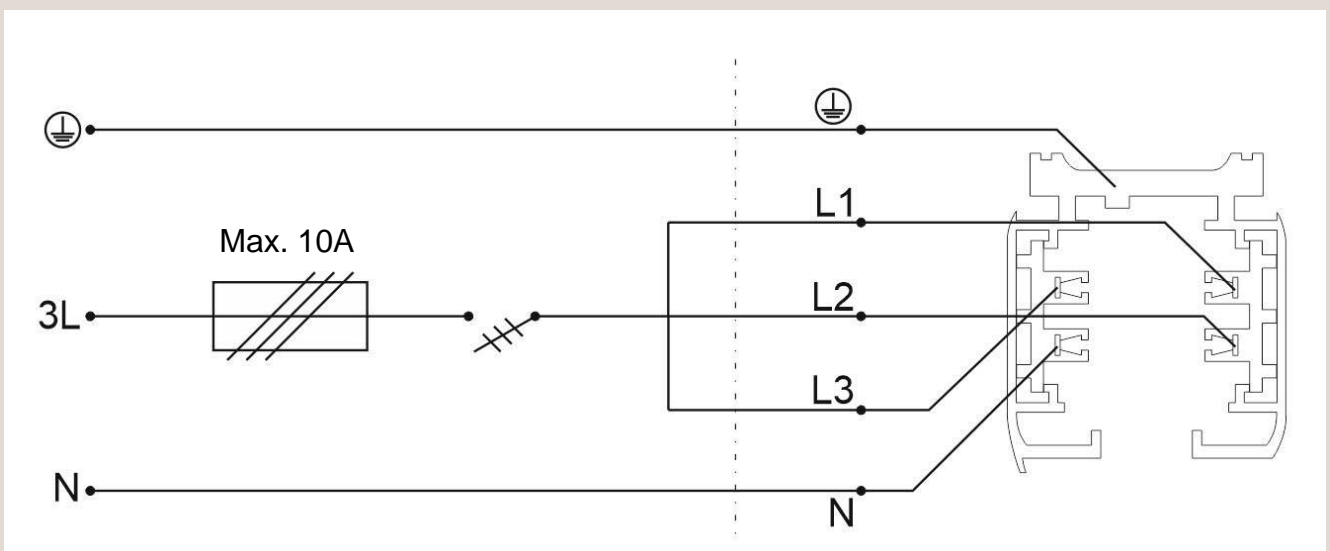

One line, which is controlled by a three-key switch.

TROUBLESHOOTING

Malfunction	Cause	Troubleshooting
The lamp does not work	No contact in joints	Install the lamp on the track until the adapter is in full contact with the current-carrying cores
		Check the input cable connection terminals, the connection of the power input terminals to the track, and other connections.
	Contact the seller for a replacement under warranty	Contact the seller for a replacement under warranty
	Lamp failure	
The light is flashing or dimly lit when off	To control the lighting circuit, a switch with key backlighting is installed, or a motion (light) detector is used	Replace the switch with a model without key backlighting, or which has an additional resistor in its design. Use motion (light) detector only with relay output
Unstable glow, flickering, extraneous sound	A dimmer is installed in the power circuit	Remove the dimmer from the circuit, replace it with a switch
	Faulty power supply	Contact the seller for warranty service or replacement

STORAGE

The goods are stored in packaging indoors in the absence of an aggressive environment. Storage temperature in the range from -20°C to +70°C and relative air humidity not more than 95%. Direct exposure to moisture is not allowed.

TRANSPORTATION

The packaged product is suitable for transportation by sea, rail, road and air.

DISPOSAL

Do not dispose the product with the regular household waste!
Products must be disposed according to the directive on electrical and electronic devices at local collection points for such devices!

WARRANTY

The warranty for the product is 24 months from the date of sale, the date is established on the basis of documents establishing the fact of sale.

Warranty service is provided if the malfunction occurred due to the defect in workmanship, and also subject to all the rules of operation, transportation and storage given in this manual.

The warranty is not valid in the following cases: if the product has been used for purposes that do not correspond to its intended use; the defect arose after the transfer of the goods to the consumer and is caused by incorrect or careless handling, non-compliance with the requirements given in this manual. And also in cases of force majeure, including: fire, flood, high-voltage discharges and other natural disasters, accidents and deliberate actions of third parties that caused the product to malfunction.

MANUFACTURER

Maytoni GmbH, Feldstiege 98, Münster, Germany, 48161

IMPORTER

Maytoni GmbH, Feldstiege 98, Münster, Germany, 48161

www.maytoni.de
Developed in Germany.
Made in China.
No expiry date.

